

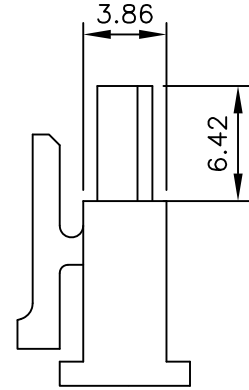

C **YI** US E182481

REV	DESCRIPTION	DATE
A1	EN000629-1	2011.06.29

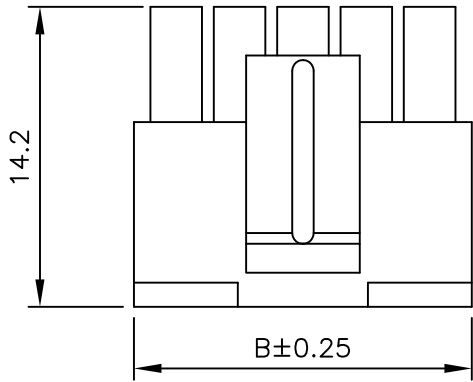
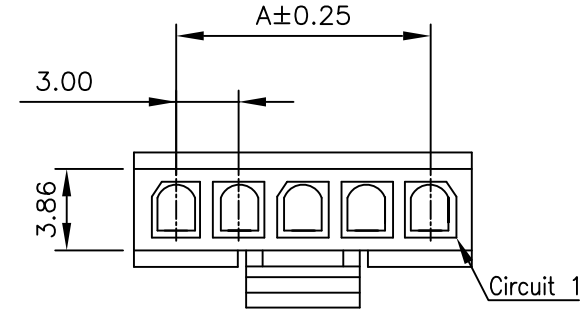

NOTES

Available in 02 through 24 Circuits
 Material: Nylon 66 UL94V-0
 Accepts YY-5750-T-A Crimp Terminal
 Mates with YY-5950-WSS or YY-5950-WRS Series Wafer or YY-5850-HS-A Series Housing

ORDERING INFORMATION

YY-5750 - H ** S - A
 1 2 3 4

1. H : Housing
2. No. of Circuits 02~12
3. S : Single Row
4. A : A Type

Circuits	Dimension mm		Circuits	Dimension mm	
	A	B		A	B
2	3.00	7.00	8	21.00	25.00
3	6.00	10.00	9	24.00	28.00
4	9.00	13.00	10	27.00	31.00
5	12.00	16.00	11	30.00	34.00
6	15.00	19.00	12	33.00	37.00
7	18.00	22.00			

TOLERANCE		Young Yak Enterprise Co., Ltd.			
X.	--	TITLE 3.0mm(.118") Pitch Wire to Wire Housing			
X.X	±0.40				
X.XX	±0.25				
X.XXX	±0.08				
ANGULAR	--				
APPROVALS					
DRAWN	Frank 29-June-2011	VIEW	SCALE	PART NO.	REV.
CHECKED	Denise 29-June-2011		F	YY-5750-H**S-A	A1
APPROVED	Jessica 29-June-2011	UNIT	SIZE	DWG NO.	SHEET
		MM	A4	YY-5750-H**S-A-086	1 OF 1





C **YI** US E182481

REV	DESCRIPTION	DATE
A1	EN000629-1	2011.06.29

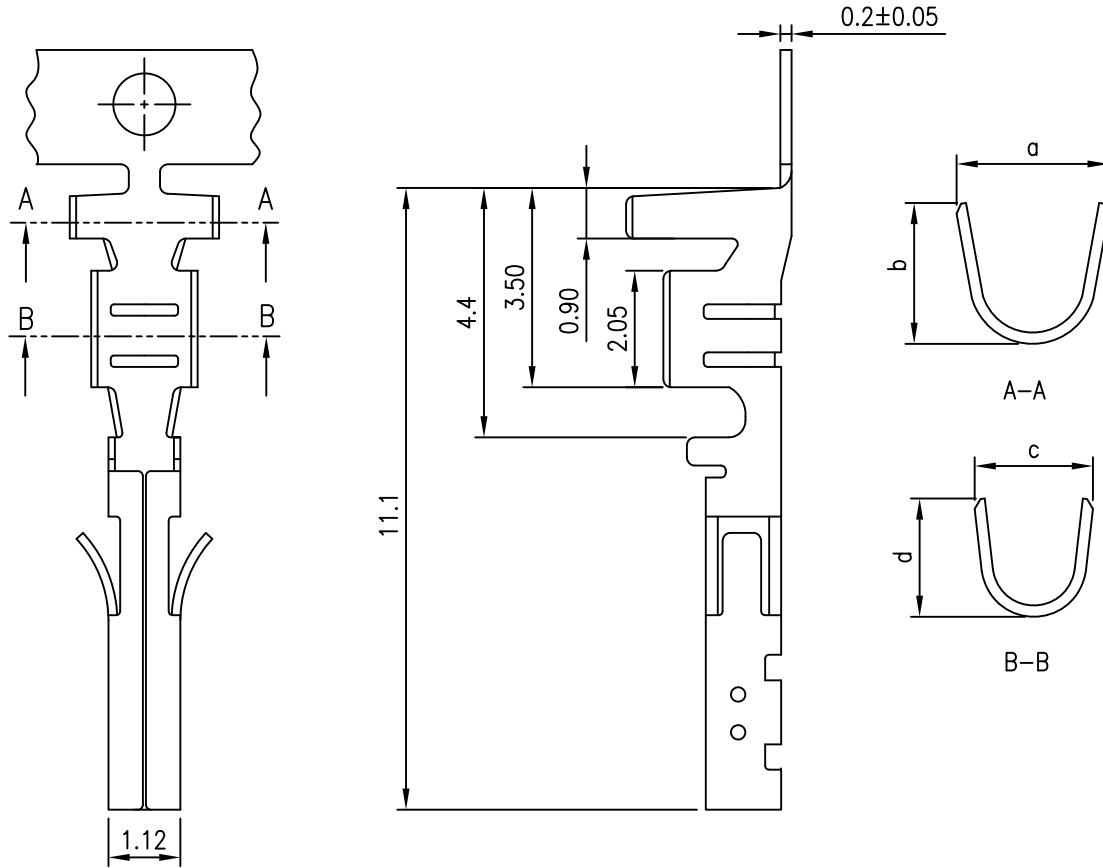

NOTES

Used in YY-5750-H-A Series Housing
 Material : Phosphor Bronze
 Finish : Tin-Plated or Gold-Plated
 Thickness: 0.2mm

ORDERING INFORMATION

YY-5750 - T ** P * - A
 1 2 3 4 5

1. T : Terminal
2. TA : Tin , Pre-tinned
GB : Gold
3. Material
P : Phosphor Bronze
4. S : AWG #26~30
L : AWG #20~24
5. A : A Type

TYPE	Wire Range	Wire Range				Insulation O.D.(mm)	Qty/reel
		a	b	c	d		
L	AWG #20~24	2.7	2.5	2.1	2.1	1.85(MAX)	10,000PCS
S	AWG #26~30	2.4	1.9	1.8	1.6	1.27(MAX)	10,000PCS

TOLERANCE					
X.	--	Young Yak Enterprise Co., Ltd. TITLE 3.0mm(.118") Pitch Wire to Wire Terminal			
X.X	±0.25				
X.XX	±0.15				
X.XXX	±0.05				
ANGULAR	--				
APPROVALS					
DRAWN	Frank 29-June-2011	VIEW	SCALE	PART NO.	REV.
CHECKED	Denise 29-June-2011		F	YY-5750-T**P*-A	A1
APPROVED	Jessica 29-June-2011	UNIT	SIZE	DWG NO.	SHEET
		MM	A4	YY-5750-T**P*-A-085	1 OF 1





C **YI** US E182481

REV	DESCRIPTION	DATE
A1	EN020103-2	2013.01.03

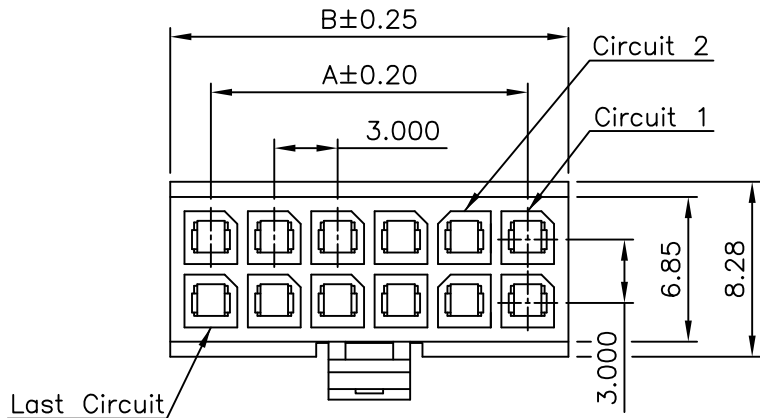

NOTES

Available in 02 through 24 Circuits
 Material: Nylon 66 UL94-V0
 Accepts YY-5750-T Crimp Terminal
 Mates with YY-5950-W**S or YY-5950-W**R Series Header

ORDERING INFORMATION

YY-5750 - H **
 1 2

- 1. H : Housing
- 2. No. of Circuits 02~24

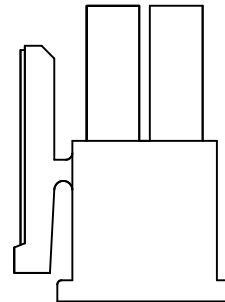
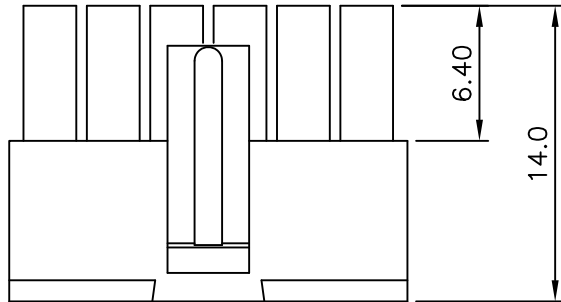

4~24PIN

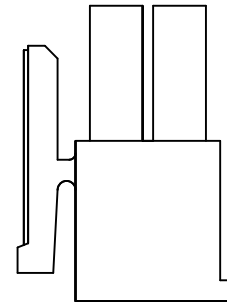

2PIN

Circuits	Dimension mm		Circuits	Dimension mm	
	A	B		A	B
2	--	3.85	14	18.0	21.85
4	3.0	6.85	16	21.0	24.85
6	6.0	9.85	18	24.0	27.85
8	9.0	12.85	20	27.0	30.85
10	12.0	15.85	22	30.0	33.85
12	15.0	18.85	24	33.0	36.85

TOLERANCE	
X.	--
X.X	±0.25
X.XX	±0.15
X.XXX	±0.05
ANGULAR	--



TITLE
 3.0mm(.118") Pitch
 Wire to Board Housing

APPROVALS		VIEW	SCALE	PART NO.	REV.
DRAWN	Frank		F	YY-5750-H**	A1
CHECKED	Kang				
APPROVED	Denise	UNIT	SIZE	DWG NO.	SHEET
		MM	A4	YY-5750-H**-014	1 OF 1





C **YAK** US E182481

REV	DESCRIPTION	DATE
A1	EN990305-1	2010.03.05
A2	EN201408180001	2014.08.18

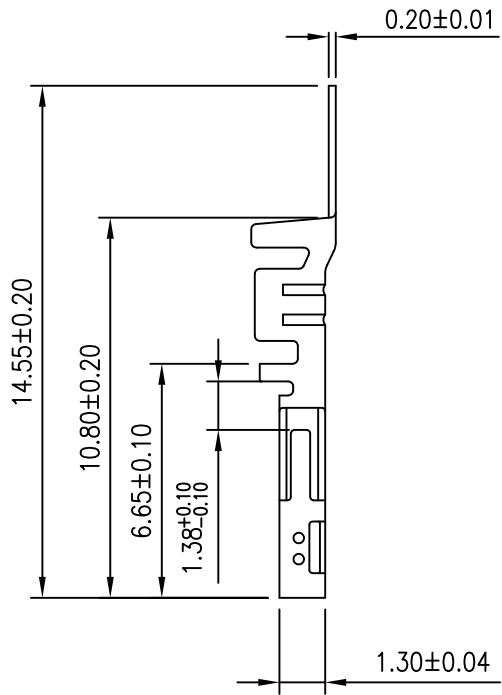
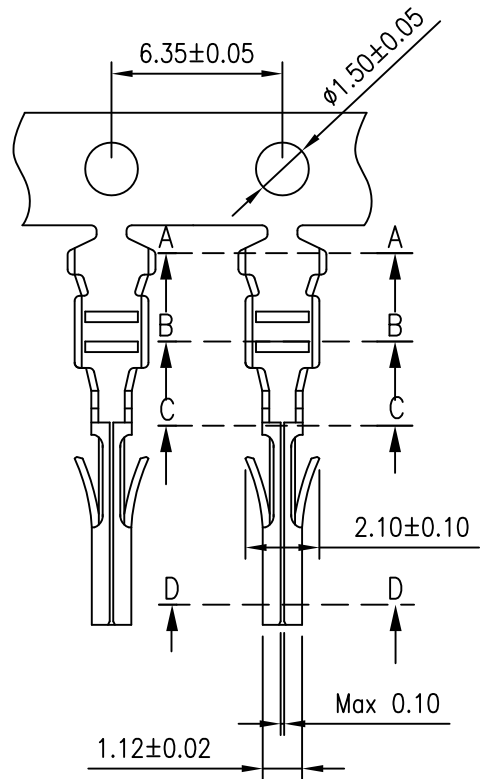

NOTES

Used in YY-5750-H Series Housing
 Accepts AWG #20~24 Wire Range
 Insulation O.D.= 1.75 mm(max)
 Material : Phosphor Bronze or Brass
 Finish : Tin-Plated or Gold-Plated
 Qty/reel: 10,000 PCS
 Thickness: 0.2mm

ORDERING INFORMATION

YY-5750 - T * * * L
 1 2 3 4

- T : Terminal
- TB : Tin , Stamping before Plated
GB : Gold
- Material
□ : BRASS
P : Phosphor bronze
- L : 20~24AWG

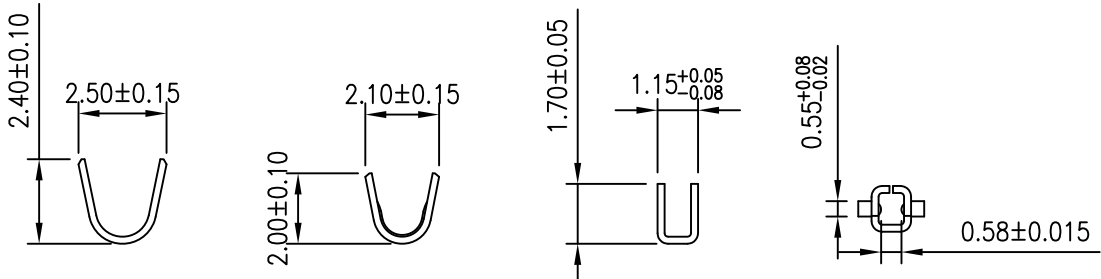

YOUNG YAK
 2014.08.18
 ISSUED

TOLERANCE	
X.	--
X.X	±0.15
X.XX	±0.10
X.XXX	±0.05
ANGULAR	--
APPROVALS	
DRAWN	JC
18-August-2014	
CHECKED	Denise
18-August-2014	
APPROVED	Jessica
18-August-2014	



TITLE
 3.0mm(.118") Pitch
 Wire to Board Terminal

DRAWN	VIEW	SCALE	PART NO.	REV.
JC		F	YY-5750-T***L	A2
18-August-2014				
CHECKED	UNIT	SIZE	DWG NO.	SHEET
Denise	MM	A4	YY-5750-T***L-B47	1 OF 1
18-August-2014				
APPROVED				
Jessica				
18-August-2014				